



Kuala Lumpur
C i t y C e n t r e

FACT SHEET



Sensuous Understated Simplicity



The Development

The Mews is about sensuous living, done with high safety standards.

Security, Convenience, Storage and Pampering are priorities for the extraordinary metro living experience.

Serviced apartments, with 5-star hospitality services provided by E&O Concierge.

A unique serviced apartment that bears E&O trademark of distinction.

Land Owner & Developer

KCB Trading Sdn Bhd
(Wholly-owned by Eastern and Oriental Berhad)

Land Tenure

Freehold

Land Designation

Commercial title

Development Type

Service Apartment

Total Development Area

1.29 acres

Total Tower

2

Total No. of Storey

38 Storeys

Total Units

256 units

List Price Range RM1.35 million – RM4.51 million, averagely RM1.9 million

List Price PSF RM1,500 psf – RM1,800 psf, averagely RM1,600 psf

Development Details

Design Types	Type	Size	Car Park
1 Bedroom (A)	1 Bedroom 1 Bathroom	86 sq.m 923 sq.ft	1
1 Bedroom (A1)	1 Bedroom 1 Bathroom	86 sq.m 922 sq.ft	1
2 Bedrooms (B)	2 Bedrooms 2 Bathrooms	116 sq.m 1,251 sq.ft	2
2 + 1 Bedrooms (C)	2+1 Bedrooms 2 Bathrooms	136 sq.m 1,459 sq.ft	2
3 + 1 Bedrooms (D)	3 +1 Bedrooms 3+1 Bathrooms	191 sq.m 2,058 sq.ft	3
Penthouse (E1)	4 Bedrooms 4 + 1 Bathrooms	225 sq.m 2,417 sq.ft	4
Penthouse (E2)	4 Bedrooms 4 + 1 Bathrooms	244 sq.m 2,623 sq.ft	4

Maintenance Fee RM0.55 (Inclusive of sinking fund)

Expected SPA Signing Q2 2013

Expected Completion 48 months from SPA date

Bumi Quota 30%

Defect Liability 24 months from completion

Architect GDP Architects

Landscape Architect Seksan Design

Apartment Interior Features

- Walk-in wardrobes
- Full length shoe cabinet
- Fully-fitted kitchen cabinet system and electrical appliances
- Concealed ducted split air-conditioning units for living/dining and bedrooms (except utility / Maids room)
- Hot water system to all bathrooms (except powder room and maid's bathroom)

Facilities

Water Sanctuary, 6th Floor

- Gym
- Squash Courts
- Salt Water Lap Pool
- Hydro Spa Pool
- Bio Fish Pond
- Resident's Lounge
- Children's Pool
- Children's Play Ground
- Multi-purpose Hall

Rooftop Terrace and Landscape Garden, 36th Floor

- Spice Garden
- BBQ Corner
- Open Living & Dining Area
- Observation Deck
- Recreation Park

Services

- 24-Hour CCTV Surveillance
- Multi-tier Security System
- Concierge
- Shutter Service to places around KLCC
- Wifi connection in common areas

Location

Located in the heart of Kuala Lumpur, The Mews connects you to the pulse of the city. By day, gleaming malls, 5-star hotels and the soaring towers of international offices dominate the skyline. By night, the area is dotted with quaint cafés, jazz bars and fine restaurants.

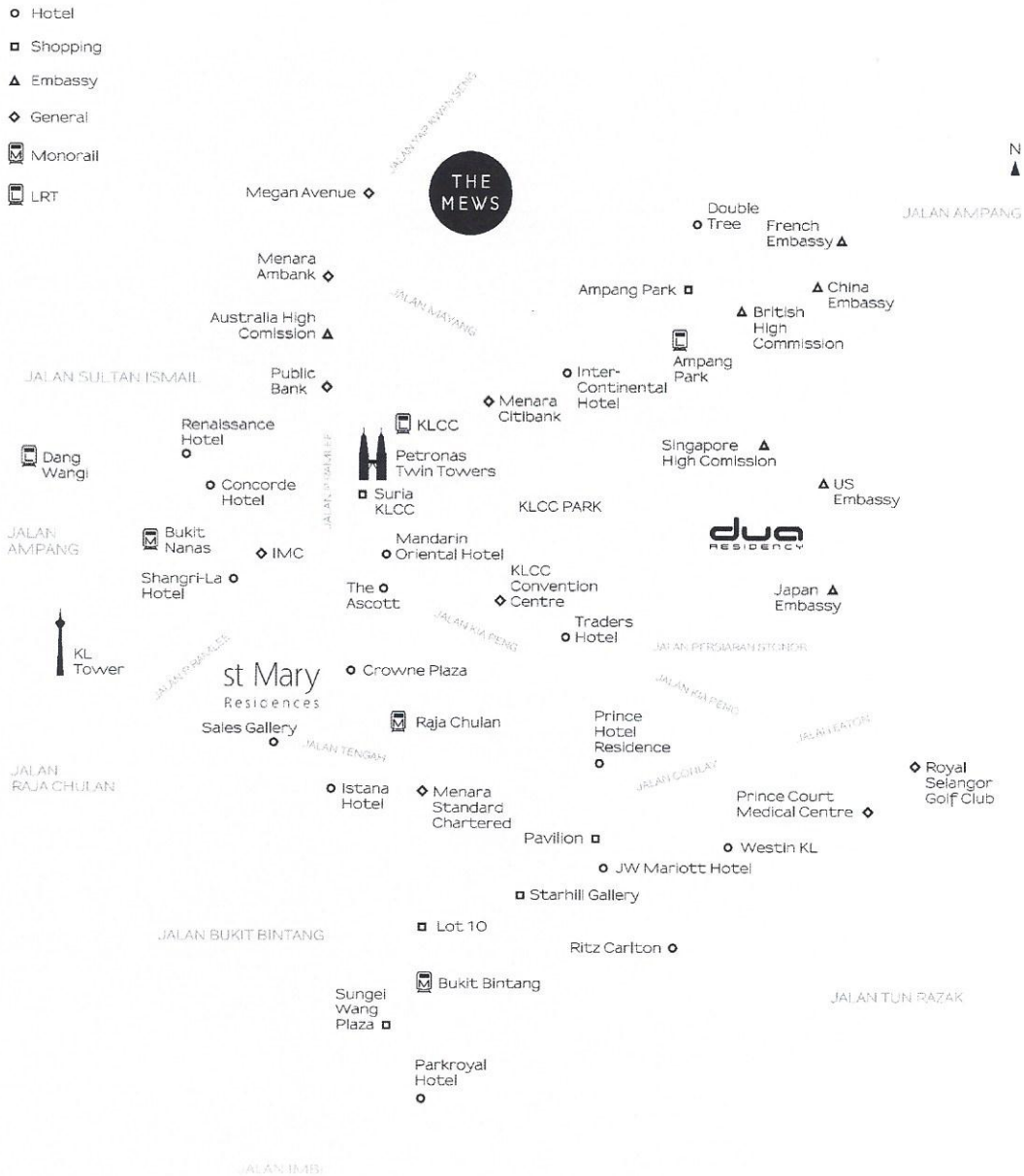

GPS Coordinates: N 03° 09.719' E 101° 42.865'

Local Vicinity



Within this prime urban centre, Kuala Lumpur's other iconic landmarks – the Petronas Twin Towers, KL Tower – loom over the city.

With its strategic location, The Mews and the Kuala Lumpur City Centre (KLCC) are at the forefront of Asia's most sought-after properties.



Hospitals & Medical Centres

- Gleneagles Intan Medical Centre
- Pantai Indah Hospital
- Prince Court Medical Centre
- Tawakal Medical Centre
- Twin Tower Medical Centre



Embassies

- American Embassy
- Australian Embassy
- Belgian Embassy
- British High Commission
- Chinese Embassy
- French Embassy
- Japanese Embassy
- Singapore High Commission

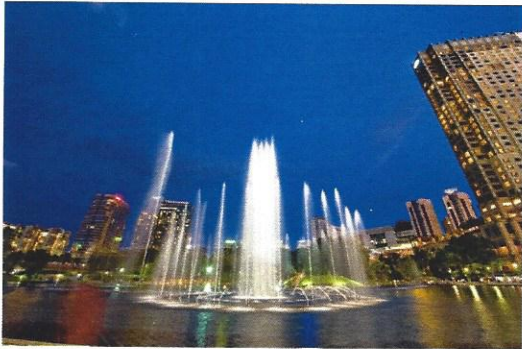

Leisure

- KLCC Park
- KL Tower
- Petronas Art Gallery
- Philharmonic Theatre
- Royal Selangor Golf Club



Shopping

- Ampang Park
- Bukit Bintang Plaza
- Lot 10
- Pavillion
- Starhill Gallery
- Sungai Wang Plaza
- Suria KLCC

Transportation



Monorail

- Raja Chulan Station
- Bukit Nanas Station

LRT

- KLCC Station
- Ampang Park Station

Road/Bus/Taxi

- The entire area is well served by buses and taxis

DIRECTIONAL VIEW – NORTH VIEW

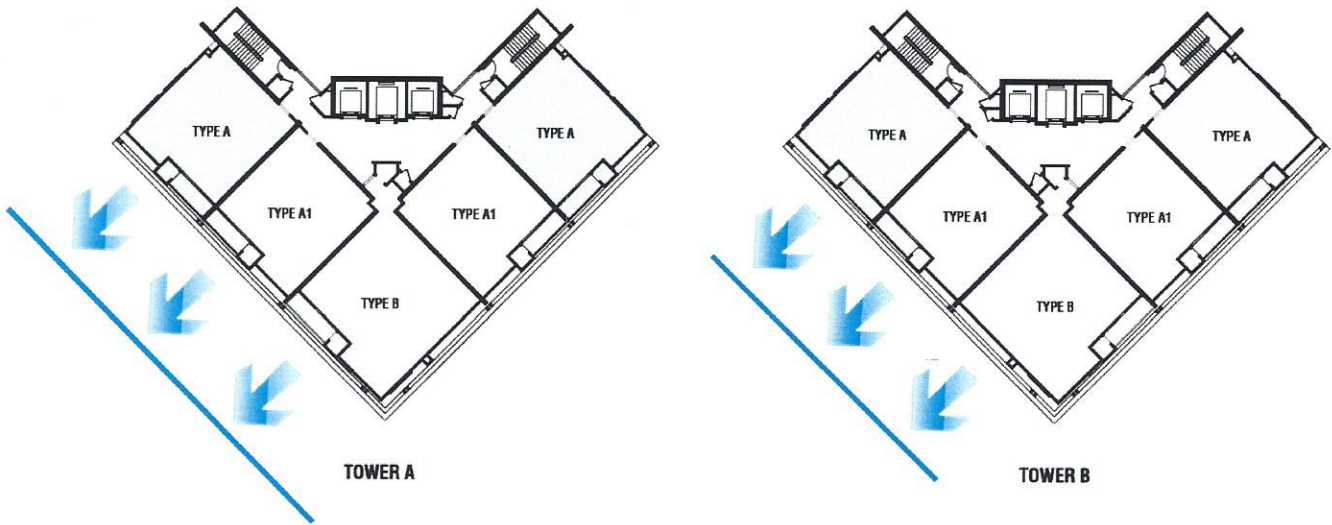

North View 

The view is for reference only, and they shall not form any part and parcel or invalidate or annul any contract of sale between the Developer and the Purchaser

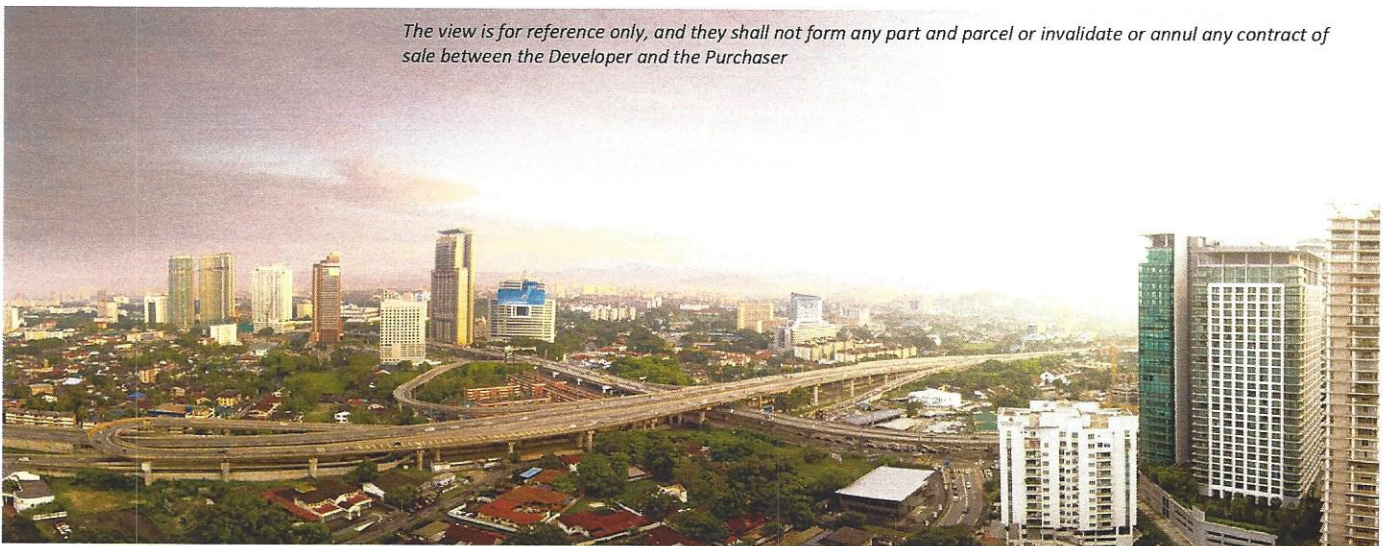

DIRECTIONAL VIEW – WEST VIEW

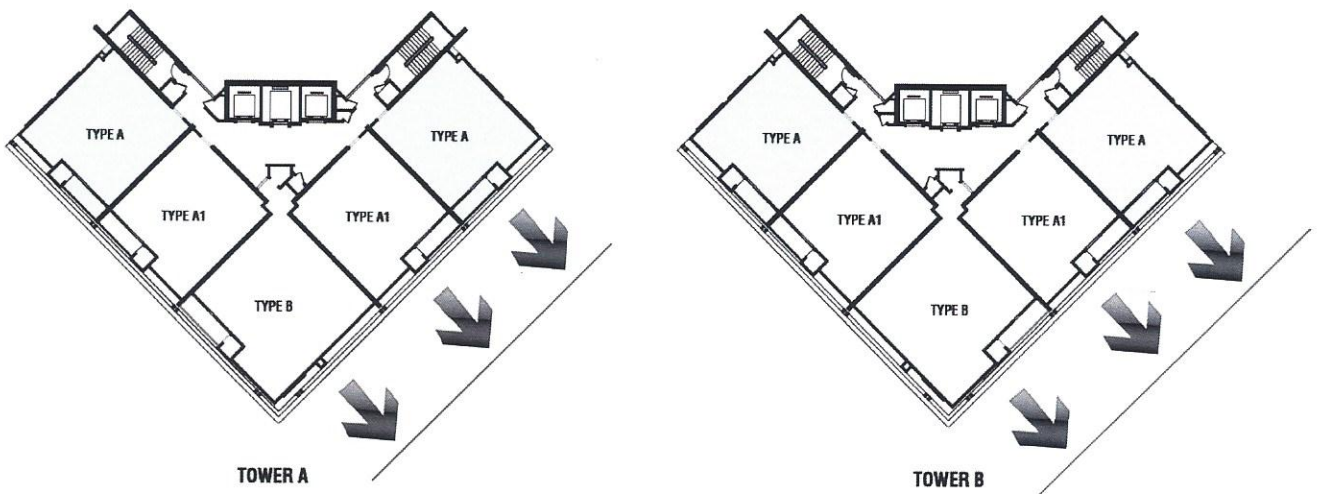

West View 

The view is for reference only, and they shall not form any part and parcel or invalidate or annul any contract of sale between the Developer and the Purchaser

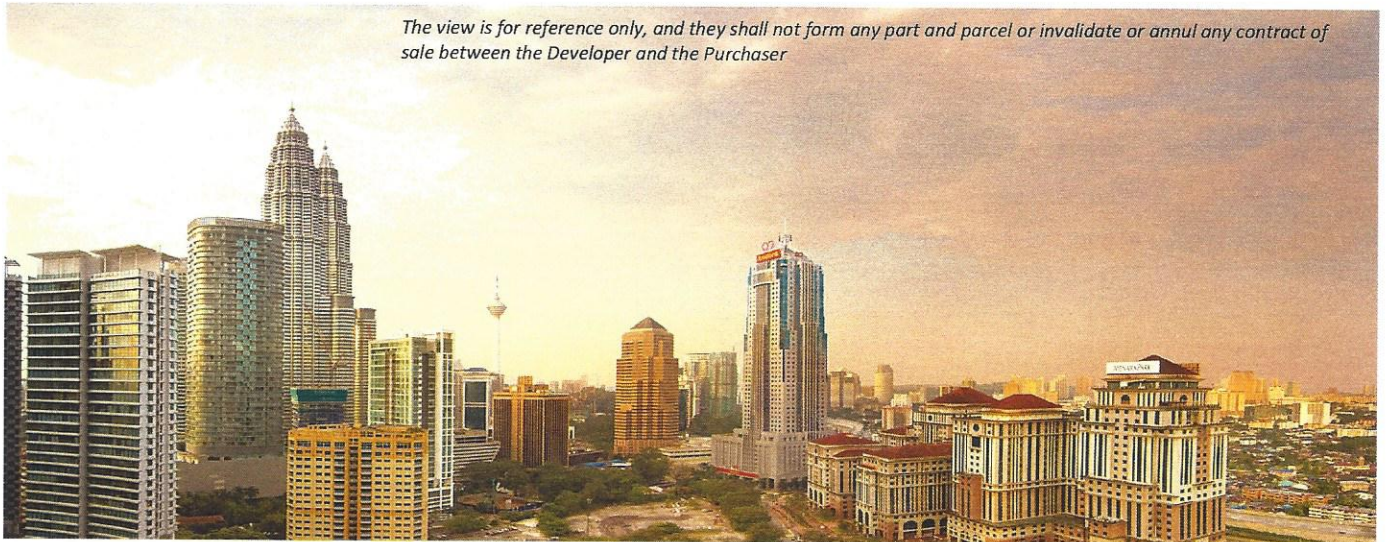

FLOOR LAYOUT

Type A , A1 , B

Level 7 – 21, Level 23 – 26

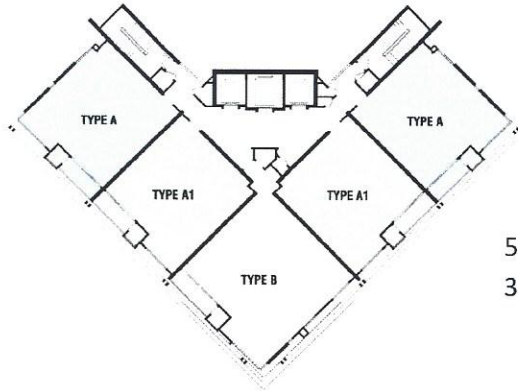

TOWER A

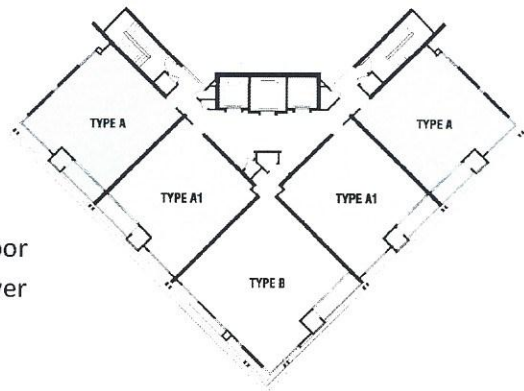

TOWER B

5 units / floor
3 lifts / tower

Type A , A1 , B

Level 22

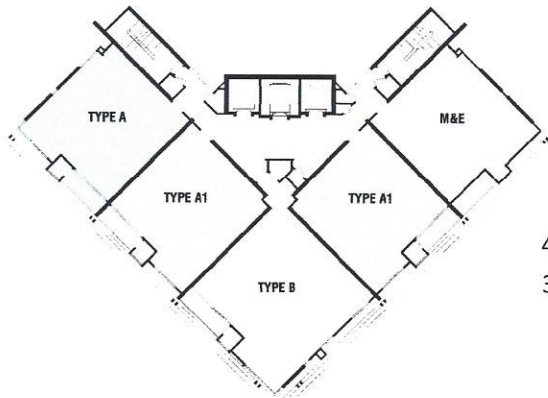

TOWER A

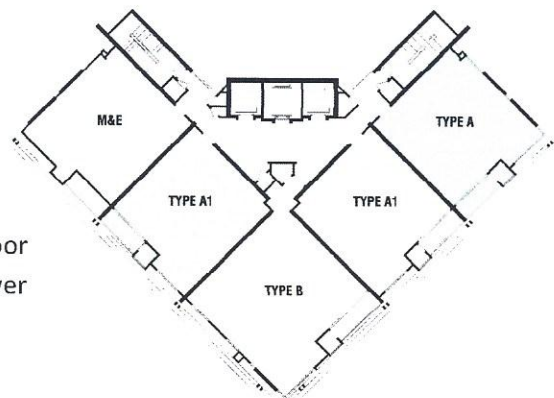

TOWER B

4 units / floor
3 lifts / tower

Type A - 1 Bedroom

Built-Up: 923 sq.ft. / 86 sq.m.

Level 7 - 26

Bedroom: 1

Bathroom: 1



Floor Area - Type A		
Location	(sq.ft.)	(sq.m.)
Master Bed	230	21.41
Dressing	61	5.65
Master Bath	134	12.44
Kitchen	102	9.50
Dining	139	12.92
Living	180	16.76

Type A1 - 1 Bedroom

Built-Up: 922 sq.ft. / 86 sq.m.

Level 7 - 26

Bedroom: 1

Bathroom: 1

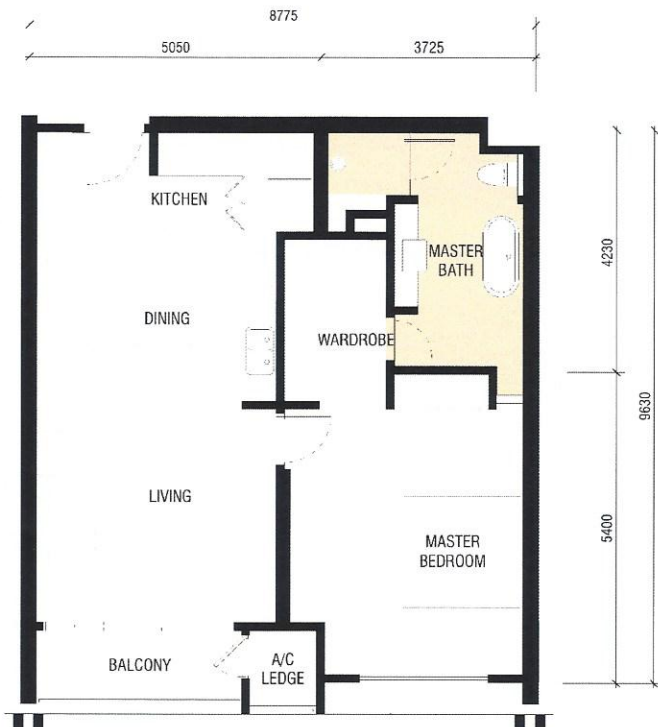

Floor Area - Type A1		
Location	(sq.ft.)	(sq.m.)
Master Bed	227	21.06
Dressing	61	5.65
Master Bath	137	12.72
Kitchen	102	9.50
Dining	139	12.92
Living	180	16.76

Type B – 2 Bedrooms

Level 7 – 26

Built-Up: 1,251 sq.ft / 116 sq.m

Bedroom: 2 Bathroom: 2

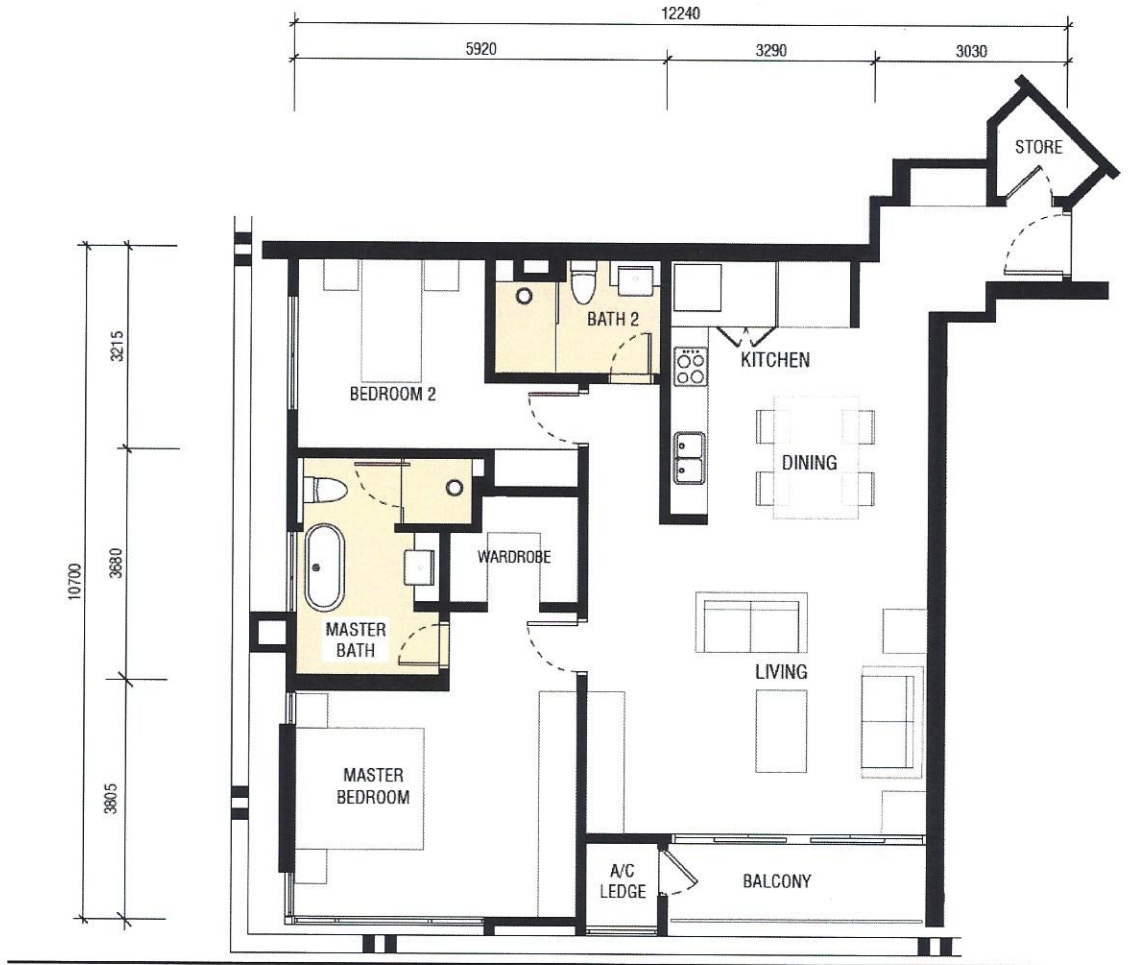

Floor Area - Type B		
Location	sq.ft.	sq.m.
Master Bed	216	20.04
Dressing	40	3.76
Master Bath	103	9.58
Bed Room 2	137	12.75
Kitchen	147	13.69
Dining	181	16.78
Living	261	24.23

FLOOR LAYOUT
Type C & Type D
Level 27 – 35

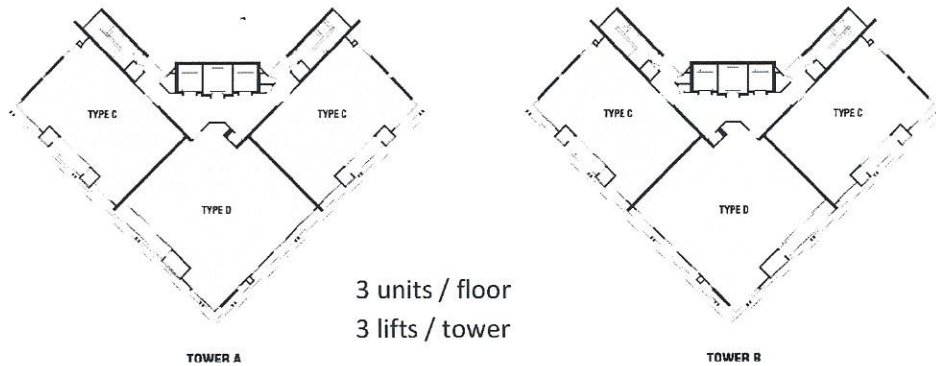

Type C – 2+1 Bedrooms
 Level 27 – 35
 Built-Up: 1,459 sq.ft / 136 sq.m
 Bedroom: 2+ 1

Bathroom: 1

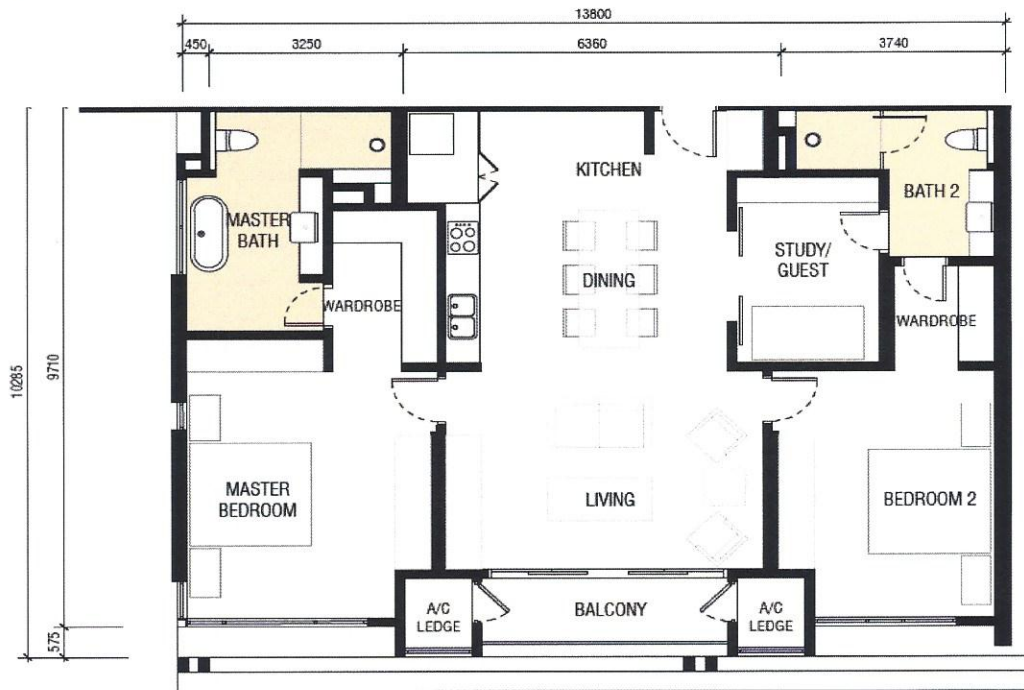

Floor Area - Type C		
Location	sq.ft.	sq.m.
Master Bed	21.41	230
Dressing	5.65	61
Master Bath	12.43	134
Bed Room 2	21.52	232

Floor Area - Type C		
Location	sq.ft.	sq.m.
Kitchen	10.86	117
Dining	15.11	163
Living	21.41	230

Type D – 3+1 Bedrooms

Level 27 – 35

Built-Up: 2,058 sq.ft / 191 sq.m

Bedroom: 3+ 1

Bathroom: 3 +1



Floor Area - Type D		
Location	sq.ft.	sq.m.
Master Bed	255	23.73
Dressing	70	6.48
Master Bath	129	12.00
Bed Room 2	190	17.67
Bed Room 3	167	15.50
Kitchen	219	20.34
Dining	196	18.21
Living	266	24.69

FLOOR LAYOUT
Type E - Penthouse
Level 36

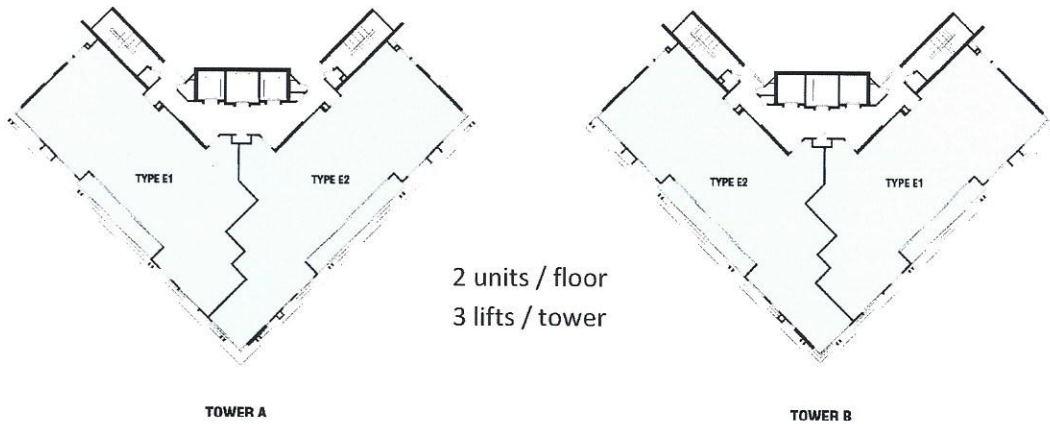

Type E1- Penthouse

Level 36
 Built-Up: 2,417 sq.ft / 225 sq.m
 Bedroom: 4 Bathroom: 4 +1

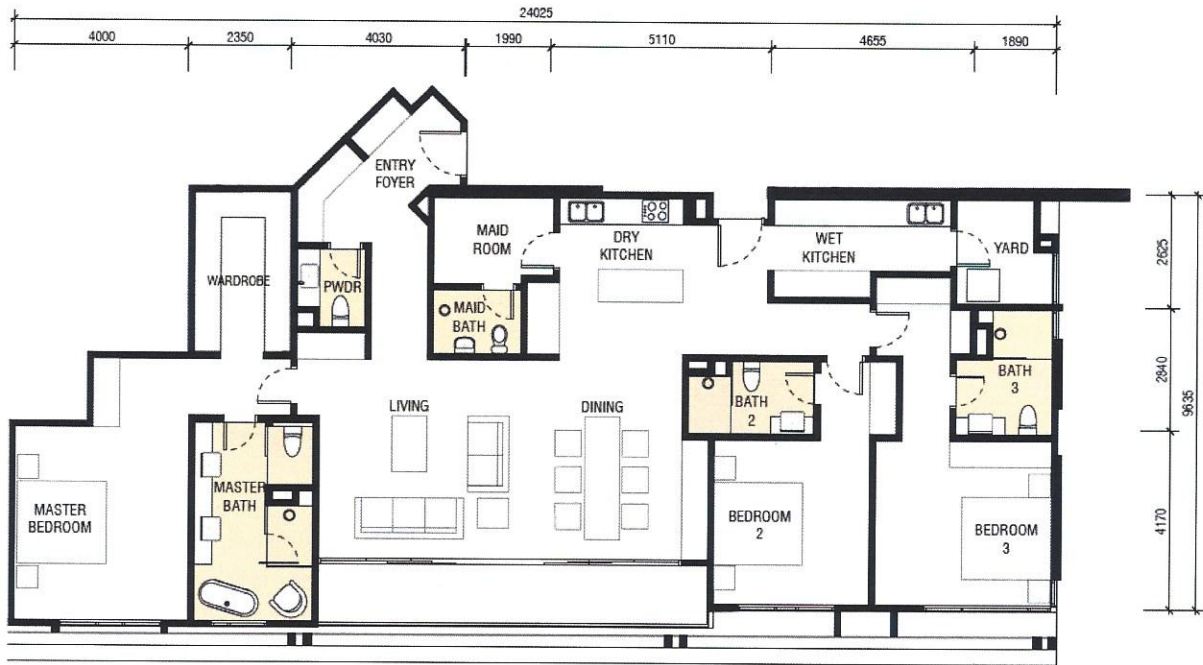

Floor Area - Type E1		
Location	sq.ft.	sq.m.
Master Bed	278	25.88
Dressing	99	9.23
Master Bath	146	13.59
Bed Room 2	195	18.12
Bed Room 3	248	23.03

Floor Area - Type E1		
Location	sq.ft.	sq.m.
Wet Kitchen	99	9.21
Dry Kitchen	241	22.41
Dining	212	19.70
Living	295	27.39
Entry Foyer	110	10.18

Type E2 – Penthouse

Level 36

Built-Up: 2,623 sq.ft / 244 sq.m

Bedroom: 4 + 1 Bathroom: 4 + 1

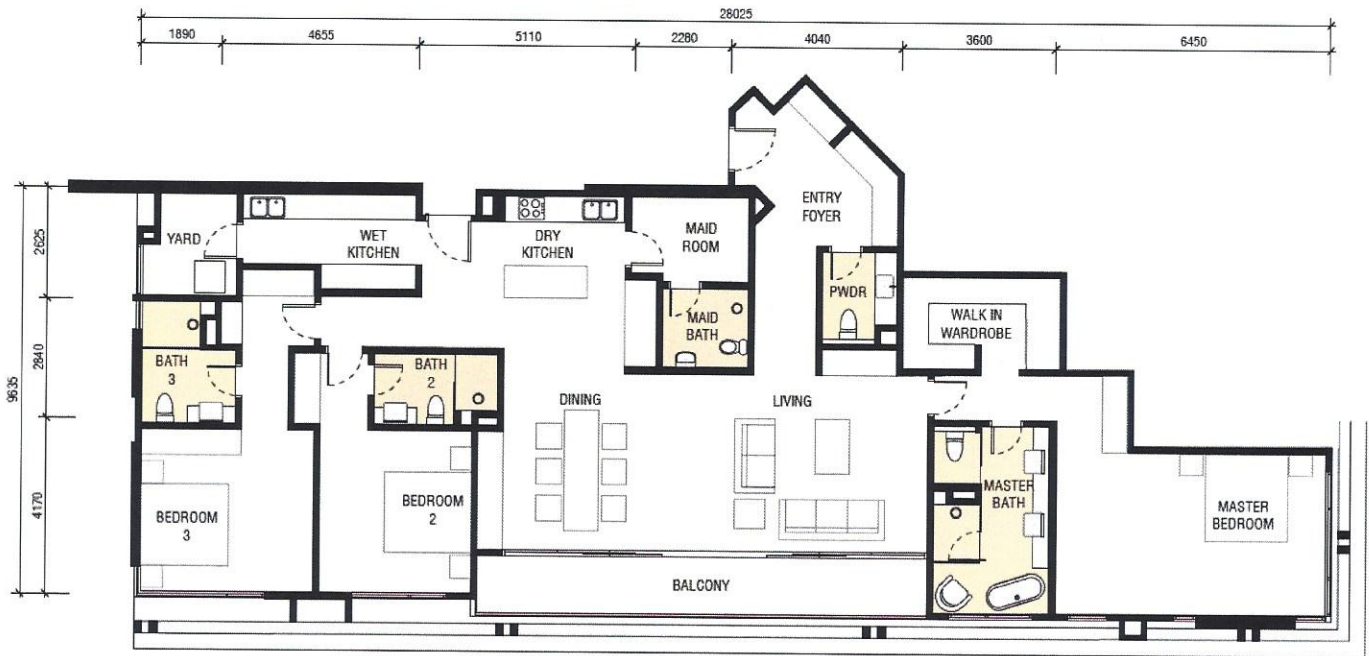

Floor Area -Type E2		
Location	sq.ft.	sq.m.
Master Bed	33.86	364
Dressing	8.82	95
Master Bath	12.95	139
Bed Room 2	18.25	196
Bed Room 3	23.13	249
Wet Kitchen	9.16	99
Dry Kitchen	23.97	258
Dining	18.06	194
Living	32.89	354
Entry Foyer	12.06	130

Specification

Structure	Reinforced Concrete
Brick	Clay Brick
Ceiling	Fibrous Plaster / Skim Coat & Paint
Windows	Aluminium Powder Coated
<u>Doors</u>	
Main Door	Fire Door
Others	Timber Solid Semi Core Door /Powder Coated Sliding Door
Ironmongery	Quality Locksets
<u>Floor Finishes</u>	
Living, Dining, Kitchen,	Timber Flooring
Bedrooms	Timber Flooring
Master Bathrooms	Stone / Tiles
Bathrooms	Tiles
Utility / Maid's Room	Tiles
Wet Kitchen, Maid's Room	Tiles
Balcony	Tiles
General walkway / Lift Lobby	Tiles
<u>Wall Finishes</u>	
Master Bathroom	Plaster & Paint
Secondary Bathrooms	Plaster & Paint
Others	Plaster & Paint
<u>Sanitary</u>	
Master Bathroom	Long Bath, Water Closet, and Wash Basin with Fittings & Accessories
Powder Room & Bathrooms	Water Closet, Wash Basin with Fittings & Accessories
<u>Extra</u>	
Kitchen	Kitchen Cabinet with Electric Oven, Microwave Oven, Hob & Hood, Refrigerator, Washing Machine, Dryer and Waste Disposal
Hot Water System	Bathrooms (except powder room and maid's bathroom)
<u>Others</u>	
Ceiling Fan	Living, Dining and all Bedrooms
Air Conditioning	Living, Dining and all Bedrooms (except utility / maid's room)
Wardrobe	Walk-in Wardrobe for Master Bedroom Full Length Shoe Storage

All measurements are approximate and illustrations are artist's impressions only. All layout, specifications and information contained herein are also subject to amendments as may be required by the authorities and/or the Developer's project consultant without prior notices; hence, they shall not form any part and parcel or invalidate or annul any contract of sale between the Developer and the Purchaser.

Technical Information

- Overall Building Height 1,601m from Ground Level
- Ceiling Height (net)
 - Bedroom/ Living/ Dining (skim coat) 3.4m / 11ft
 - Toilets 2.6m / 8.5ft
- Main door Height 2.4m / 8ft
- Distance from main road entrance to development's entrance
 - Front road (main access) 59m / 19ft
 - Back Road (service access) 58m / 19ft
- Pool Size
 - Lap Pool 30m (length) x 7.8 (width),
 - Swallow Pool 5.5m (length) x 7.8 (width)
- Car park size
 - Provided 2.5m (width) x 5.0m (length)
 - Normal Size 2.4m (width) x 4.8m (length)

Panel Banks
(DIBS Entitlement)

United Overseas Bank
OCBC Bank
CIMB Bank
RHB Bank
HSBC Bank

Panel Legal Firm

Yeap, Yong & Amy
No. 25, Jalan Pandan Indah 4/6A
Pandan Indah
55100 Kuala Lumpur
Tel: +603 4291 7033 Fax: +603 4292 6033

J.M. Chong, Vincent Chee & Co.
Suite 9.03, 9th Floor
Menara EON Bank
288, Jalan Raja Laut
50350 Kuala Lumpur
Tel: +603 2694 9988 Fax: +603 2694 3399

Logan Sabapathy & Co.
Suite 2002, Wisma Hamzah-KH
No 1 Leboh Ampang
50100 Kuala Lumpur
Tel: +603 2031 9780 Fax: +603 2031 9781